

# FOREST FIRE DETECTION USING MACHINE LEARNING WITH RASPBERRY PI

Gopinath. S<sup>1</sup>, Hari. K<sup>2</sup>, Prasanth. A<sup>3</sup>, Raakshesh. V<sup>4</sup>, Mohan. J<sup>5</sup>

<sup>1</sup>B.E Student, Department of ECE, SRM Valliammai Engineering College (Affiliated to Anna University),TamilNadu, India, gopinath6pro@gmail.com

<sup>2</sup>B.E Student, Department of ECE, SRM Valliammai Engineering College (Affiliated to Anna University), Tamil Nadu, India, haricpt2@gmail.com

<sup>3</sup>B.E Student, Department of ECE, SRM Valliammai Engineering College (Affiliated to Anna University), Tamil Nadu,India, prasanthanbazhagan31@gmail.com

<sup>4</sup>B.E Student, Department of ECE, SRM Valliammai Engineering College (Affiliated to AnnaUniversity), Tamil Nadu, India,raakshesh009@gmail.com

<sup>5</sup>Associate Professor, Department of ECE, SRM Valliammai Engineering College (Affiliated toAnnaUniversity), Tamil Nadu, India, mohanj.ece@valliammai.co.in

**Abstract:**laptop Vision primarily based fireplace detection utilize image process has the potential to be helpful in conditions during which standard ways cannot be adopted. the fire detection rule uses visual characteristics of fires like brightness, colour, spectral texture, spectral flicker, and edge trembling to discriminate them from different visible stimuli. There are numerous varied fireplace detection techniques like infrared device, a thermal detector, smoke detector, flame detector, and optical smoke detector. These techniques aren't constantly reliable as they are doing not perpetually notice {the fireplace the fire |the fireplace} itself however notice one or additional phenomena ensuing from fire, like smoke, heat, infrared, UV radiation or gas, that might be created in different ways and hence, produces several false alarms. By the assistance of laptop vision and image process techniques, it's achievable to get higher results than standard systems as a result of pictures will offer additional reliable data.

**Keywords:** fire, OpenCV, python, image process, Raspbian OS.

## I. INTRODUCTION

Fire will build major hazards during this agitated world. All buildings and vehicles employed in public transportation have fire protection and fire protection systems due to the accelerated variety within the fire incidents. Also, several of the companies conduct a mock exercise in each incidence of months to safeguard their staff from the fireplace. This would help them to understand what to do or what to not do once a fireplace state of affairs happens. Forests are one of the main factors in equalization the ecology. it's terribly harmful once a fireplace happens in an exceedingly forest. however, most of the time, the detection of fire happens once it cover a large region. Sometimes, it couldn't be attainable to prevent the fireplace. As a result, the harm of the surroundings is on top of foreseeable. The emission of big amount of carbon dioxide (CO2) from the forest fire damages the environment.

further because it would cause complete disappearance of rare species within the world (Al khatib, 2014). Also, it will make an effect on the weather, and this build major problems like earthquakes, significant rains, floods so on.

The forest could be a giant surface of space stuffed with trees, millions of dried leaves, woods so on. These components encourage the fire once it starts. the fire may be kindled through several reasons like warmth in summer seasons, smoking, or some parties that having fireworks. Once fire starts, it'll stay till it distinguished completely . The damage and the price for distinguish fire owing to forest fire may be reduced once the fireplace detected early as attainable. So, the fire detection is principal during this situation. Finding of the accurate location of the fireplace and causing notification to the fire authorities shortly once the incidence of fireside will build a positive impact. There are differing types of fire detection strategies utilized by the govt. authorities like satellite observance, tower observance, using sensors, optical cameras so on. There are some other techniques used for fire suppression. the key one is burning the dry areas or like in Canada; they're using flying water tanks for fire suppression. In Mideast countries, these components sweep away and burnt it in an exceedingly bound unfuelled place. But, in Australia, they supply fire in these areas and wait till it dies itself while not make any danger to the wildlife or humans. Wildfires are of the key causes of degradation of India's forests and wildlife. in step with a paper written by NRSA, it's calculable that the proportion of forest areas susceptible to forest fires annually ranges from 33% in some states to over a staggering 90% in others. Forest fires in Indian country aren't only caused due to natural processes or natural forces however conjointly as a result of human error. Indian country has recently witnessed a 100% spike (from 15,937 to 35,888) in fires that are related to human error in fair 2 years (2015-2017). These cases instead of prediction of fires, would like fast ways that to suppress it or stop it from spreading. huge areas are torched due to improper maintenance of forests.

## **II. LITERATURE SURVEY**

### ***A. Motivation***

Internet of things (IoT) is that the network of programmable software system, sensors, electronics and communication facility that helps to collect and transfer data. the target of the designed system is to alert the remote user whereas the fire accidents occur. this method is simply put in at any remote locations from wherever using is simply detected by camera. Therefore, sensors don't seem to be needed for this purpose. The Raspberry Pi controller processes the camera input and detects fireplace mistreatment heat signatures. By victimisation image process methodology, the report is mechanically generated and sends to the person straightaway once the fire is being detected using Wi-Fi. This intern triggers the emergency mode of system. blessings together with remote watching for immediate actions and sending the information at any time or place, are main attributes of this methodology.

### ***B. Generate Alert on Fire***

The main motive of using this method is to stop from the loss of life or the other damages to the company or the organization. Few years back the system that were put in square measure currently obsolete as a result of the sight fire or smoke once it reaches the maximum level and till that point the loss was already done. the fire detection system is used to detect fire in air through camera in real time watching system supported Raspberry Pi. the most feature of system is to alert generate once fire is started or reached it minimum level to stop from the loss of lives and damages of the other property or valuable things that are helpful for the company or anywhere wherever it's put in.

### *C. Surveillance system*

The fire detection system want surveillance to detect the fire and to manage it by generating an alert to the registered users on the appliance. this may be achieved by using Raspberry Pi that management the fire detection system and therefore the android application is incredibly helpful once fire is detected it generate alert and provides associate tuned in to local department. this method works on Raspberry Pi and therefore the android application. The image process algorithmic rule is functioning and it's designed on Python programming language that detects fire and send alert on the server that is connected to android. The android application receives the alert associated send notification or generate an alert on the appliance which may be seen by registered users.

### **III. RELATED WORK**

Some of antecedental reported fire detection system are supported detection smoke as a change then sent response to detector, that rings alarm. Some detectors sense heat as change and once act with a detector emergency mode is triggered that finishes up in ringing the buzzers. However, once mentioned systems have issues that decrease their importance and open the window to explore new systems. apparently, only few reports are offered in literature visual primarily based fire detection system. Most of reported issues are system obtaining broken due to heat or wire system get broken. While doing laptop vision tasks like during this project, we are able to get the knowledge concerning the article by varied techniques like image process, image models, RGB/HSV conversion strategies and HAAR cascade classifiers. The algorithmic rule we tend to use during this project is Haar Cascade Classifier, that could be a technique for detection objects in a picture simply. The Haar Cascade Classifier is associate object detection technique developed by Viola & Jones. This technique relies on Haar-like options, combined with the classifier which ends up within the cascade turning into reinforced. Haar-like options are options that area unit wide utilized in detection of objects, providing speedy extraction method and are able to represent a lower resolution image. This technique has been with success applied in several object detection applications.

The classifier is formed with coaching a cascade file from variety of positive & negative pictures, that have constant size. once assessment of the image is finished, the area that are the same as the article are marked as one whereas it marked as zero for the areas that don't match. once the coaching, the cascade is currently able to examine additional input pictures. The classifier goes on to seem across the whole image so as to seek out similar options because the cascade of the article to be detected. To find the topographic point a lot of accurately and to scale back the time taken to scan each image, the scanning window size is modified adaptively by the classifier. throughout the method of classification, the model options the optimum rectangles in accordance with the objects and therefore the scanning window.

### **IV.METHODOLOGY**

Here in fire detection, we have a tendency to are using the Haar Cascade classifier, that is extremely popular in object detection through the image or the other video feeds. Here we have a tendency to using the artificial language for Detection – Open CV – Python. Open CV (Open-Source pc Vision Library) could be a library of programming functions principally aimed toward time period pc vision. Haar-like options are digital image options used in object recognition. They owe their name to their intuitive similarity with Haar wavelets and were utilized in the primary period face detector. three basic varieties of Haar-like options: Edge features , Line features, and Four-rectangle features. The white bars represent pixels that contain components of a picture that are nearer to the

sunshine supply, and would so be “whiter” on a grayscale image. In associate degree integral image, every component represents the accumulative add of a corresponding input component with all pixels on top of and to the left of the input pixel. an integral image allows you to speedily calculate summations over image subregions.

## V. MODULES

### A. GAS SENSOR

Sensitive material of MQ-5 gas sensor is SnO<sub>2</sub>, which with lower conductivity in clean air. When the target combustible gas exists, the sensors conductivity is higher along with the gas concentration rising. Please use simple electro circuit, convert change of conductivity to correspond output signal of gas concentration. MQ-5 gas sensor has high sensitivity to Methane, Propane and Butane, and could be used to detect both Methane and Propane. The sensor could be used to detect different combustible gas especially Methane, it is with low cost and suitable for different application. We are going use Methane type of gases in demo session.

#### Specifications:

- Operating voltage :5V
- Load resistance : 20KΩ
- Heater resistance : 33Ω ± 5%
- Heating consumption : <800mw
- Sensing Resistance : 10 KΩ – 60 KΩ
- Concentration Scope : 200 – 10000ppm
- Preheat Time : Over 24 hours



**FIGURE.1. Gas Sensor**

### B. HUMIDITY SENSOR

Humidity is the presence of water in air. The amount of water vapor in air can affect human comfort as well as many manufacturing processes in industries. The presence of water vapor also influences various physical, chemical, and biological processes. Humidity Sensor Humidity measurement in industries is critical because it may affect the business cost of the product and the health and safety of the personnel. Hence, humidity sensing is very important, especially in the control systems for industrial processes and human comfort. According to the measurement units, humidity sensors are divided into two types: Relative humidity (RH)sensors and absolute humidity(moisture) sensors. Most humidity sensors are relative humidity sensors and use different sensing principles.

#### Specifications:

- Model : DHT11
- Operating Voltage : 3 - 5V
- Operating Current : 0.3mA (measuring),60uA (standby)
- Max Operating Current : 2.5mA max
- Humidity Range/Accuracy : 20 - 80% / ± 5%
- Temperature Range/Accuracy : 0 - 50°C / ± 2°C
- Sampling Rate : 1 Hz (reading every 2 seconds)
- Body Size : 15.5mm x 12mm x 5.5mm

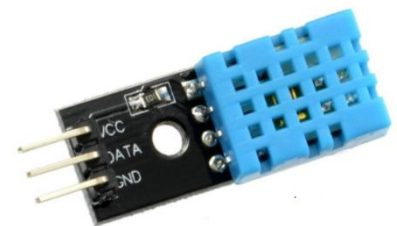

**FIGURE. 2. Humidity Sensor**

### C. WEBCAM

A webcam is a video camera which feeds its images in real time to a computer or computer network, often via USB, Ethernet or Wi-Fi. Their most popular use is the establishment of video links, permitting computers to act as videophones or videoconference stations. This common use as a video camera for the World Wide Web gave the webcam its name. Other popular uses include security surveillance and computer vision. Webcams are known for their low manufacturing cost and flexibility, making them the lowest cost form of video telephony. They have also become a source of security and privacy issues, as some built-in webcams can be remotely activated via spyware.

#### Specifications:

- Plug-and-play setup (UVC)
- Video capture: Up to 640 x 480 pixels
- Photos: Up to 1.3 megapixels (software enhanced)
- Frame rate: Up to 30 frames per second (with recommended system)
- Hi-Speed USB 2.0 certified
- Fixed focus
- Universal clip fits notebooks, LCD or CRT monitor



**FIGURE. 3. Webcam**

### D. Raspberry Pi

*Raspberry Pi4* Model B with a 1.5 GHz 64-bit quad core ARM Cortex-A72 processor, on-board 802.11ac Wi-Fi, Bluetooth 5, full gigabit Ethernet (throughput not limited), two USB 2.0 ports, two USB 3.0 ports, 1–8 GB of RAM, and dual-monitor support via a pair of micro HDMI (HDMI Type D) ports for up to 4K resolution. The version with 1 GB RAM has been abandoned and the prices of the 2 GB version have been reduced. The 8 GB version has a revised circuit board. The Pi 4 is also powered via a USB-C port, enabling additional power to be provided to downstream peripherals, when used with an appropriate PSU. But the Pi can only be operated with 5 volts and not 9 or 12 volts like other mini computers of this class.

#### Specifications:

- BROADCOM BCM2711, QUAD CORE CORTEX-A72(ARMV8) 64-BIT SOC @ 1.5GHZ.
- 4GB LPDDR4-3200 SDRAM.
- 2.4GHZ AND 5.0GHZ IEEE 802.11ac WIRELESS, BLUETOOTH 5.0, BLE.
- GIGABIT ETHERNET.
- 2 USB 3.0 PORTS; 2 USB 2.0 PORTS.



**FIGURE.4. Raspberry Pi 4 Model B**

## VI. SOFTWARE REQUIREMENTS

### A. RASPBIAN OS

Raspberry Pi OS (formerly Raspbian) is a Debian-based operating system for Raspberry Pi. Since 2015, it has been officially provided by the Raspberry Pi Foundation as the primary operating system for the Raspberry Pi family of compact single-board computers. The first version of Raspbian was created by Mike Thompson and Peter Green as an independent project. The initial released build was completed on July 15, 2012. Raspberry Pi OS is highly optimized for the Raspberry Pi line of compact single-board computers with ARM CPUs. It runs on every Raspberry Pi except the Pico microcontroller. Raspberry Pi OS uses a modified LXDE as its desktop environment with the Open box stacking window manager, along with a unique theme. The distribution is shipped with a copy of the algebra program Wolfram Mathematica and a version of Minecraft called Minecraft: Pi Edition (note that Minecraft: Pi Edition is no longer installed as of the Debian bullseye update) as well as a lightweight version of the Chromium web browser.

### *B. OpenCV*

The Internet of Things, or IoT, refers to the billions of physical devices around the world that are now connected to the internet, all collecting and sharing data. Thanks to the arrival of super-cheap computer chips and the ubiquity of wireless networks, it's possible to turn anything, from something as small as a pill to something as big as an aero plane, into a part of the IoT. Connecting up all these different objects and adding sensors to them adds a level of digital intelligence to devices that would be otherwise dumb, enabling them to communicate real-time data without involving a human being. The Internet of Things is making the fabric of the world around us smarter and more responsive, merging the digital and physical universes.

OpenCV is the huge open-source library for the computer vision, machine learning, and image processing and now it plays a major role in real-time operation which is very important in today's systems. By using it, one can process images and videos to identify objects, faces, or even handwriting of a human. When it integrated with various libraries, such as NumPy, python is capable of processing the OpenCV array structure for analysis. To identify image pattern and its various features we use vector space and perform mathematical operations on these features. The first OpenCV version was 1.0. OpenCV is released under a BSD license and hence it's free for both **academic** and **commercial** use. It has C++, C, Python and Java interfaces and supports Windows, Linux, Mac OS, iOS and Android. When OpenCV was designed the main focus was real-time applications for computational efficiency. All things are written in optimized C/C++ to take advantage of multi-core processing.

### *C. PYTHON*

Python is an interpreted, object-oriented, high-level programming language with dynamic semantics. Its high-level built-in data structures, combined with dynamic typing and dynamic binding, make it very attractive for Rapid Application Development, as well as for use as a scripting or glue language to connect existing components together. Python's simple, easy to learn syntax emphasizes readability and therefore reduces the cost of program maintenance. Python supports modules and packages, which encourages program modularity and code reuse. The Python interpreter and the extensive standard library are available in source or binary form without charge for all major platforms, and can be freely distributed.

Often, programmers fall in love with Python because of the increased productivity it provides. Since there is no compilation step, the edit-test-debug cycle is incredibly fast. Debugging Python programs is easy: a bug or bad input will never cause a segmentation fault. Instead, when the interpreter discovers an error, it raises an exception. When the program doesn't catch the exception, the interpreter prints a stack trace. A source level debugger allows inspection of local and global variables, evaluation of arbitrary expressions, setting breakpoints, stepping through the code a line at a time, and so on. The debugger is written in Python itself, testifying to Python's introspective power. On the other hand, often the quickest way to debug a program is to add a few print statements to the source: the fast edit-test-debug cycle makes this simple approach very effective.

### VII. FLOW CHART

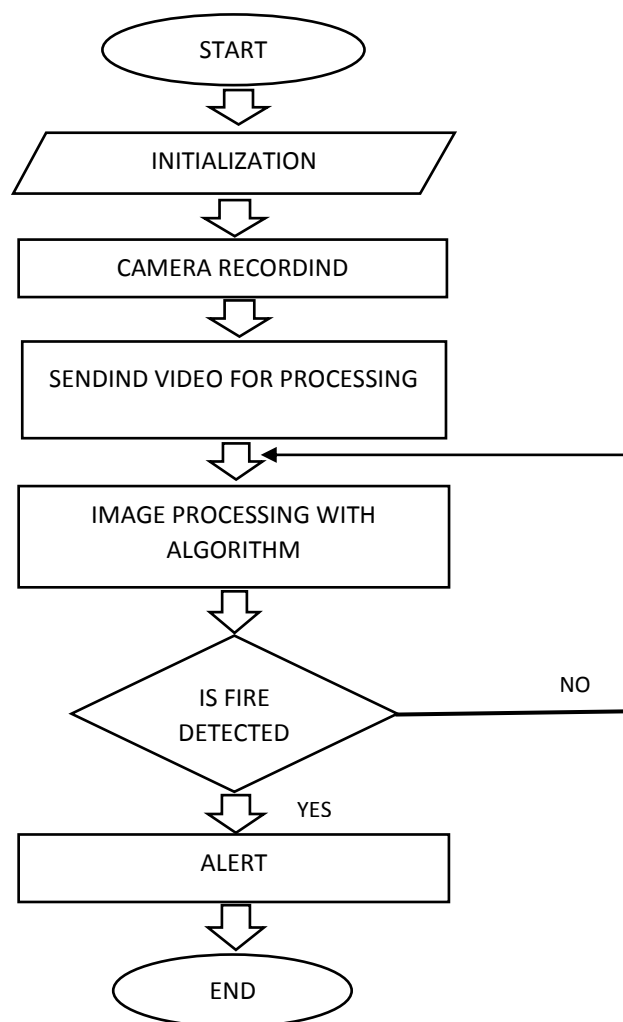

FIGURE. 5. Flow Chart

## VIII. SYSTEM ARCHITECTURE

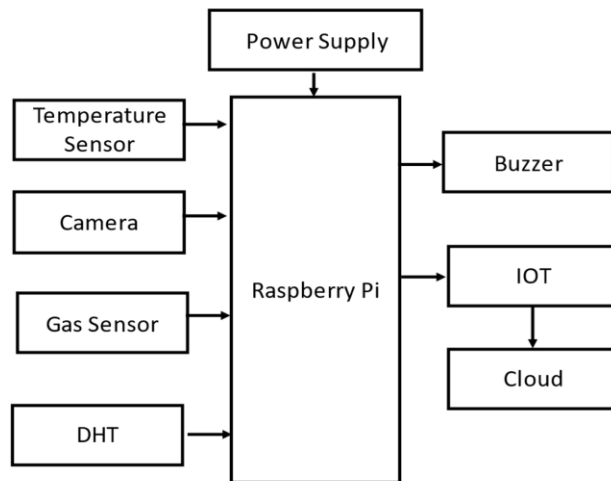

FIGURE.6. Block Diagram

## IX. HARDWARE IMPLEMENTATION

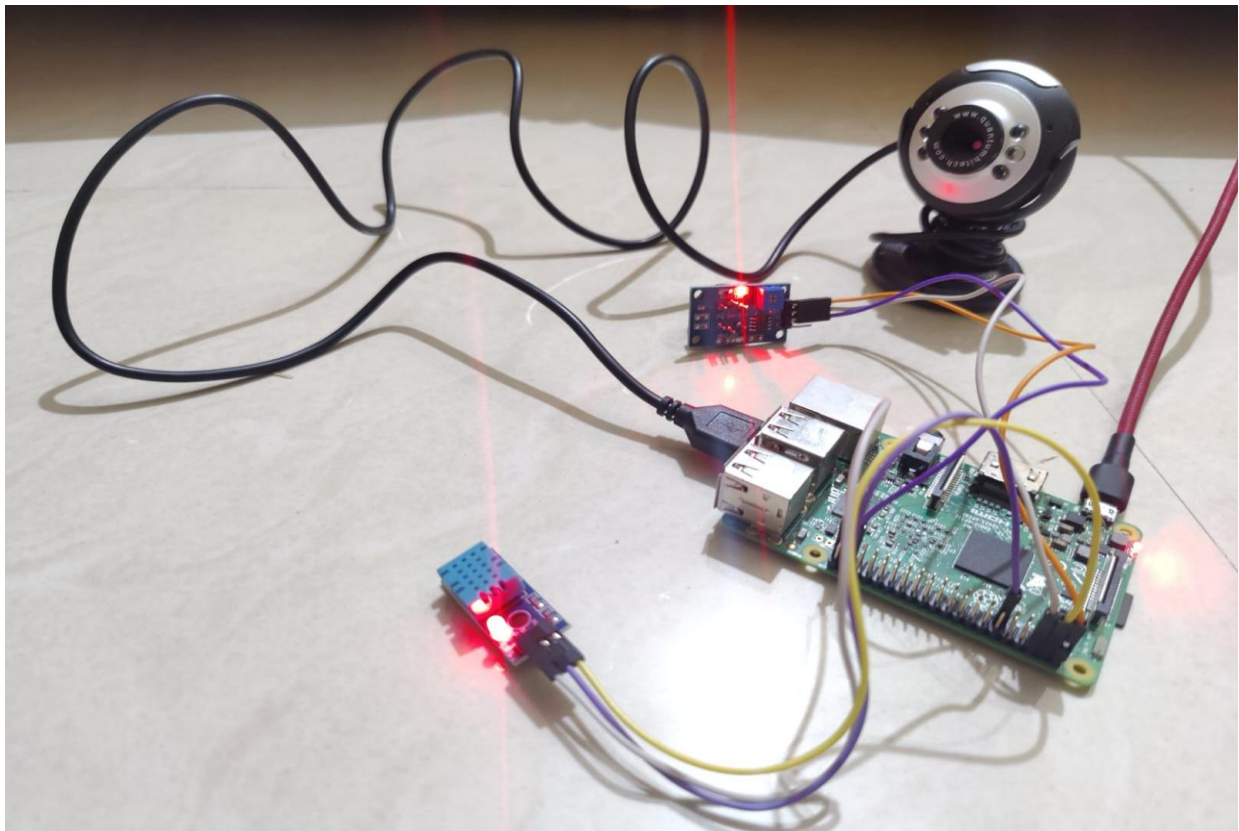

FIGURE.7.HARDWARE IMPLEMENTATION





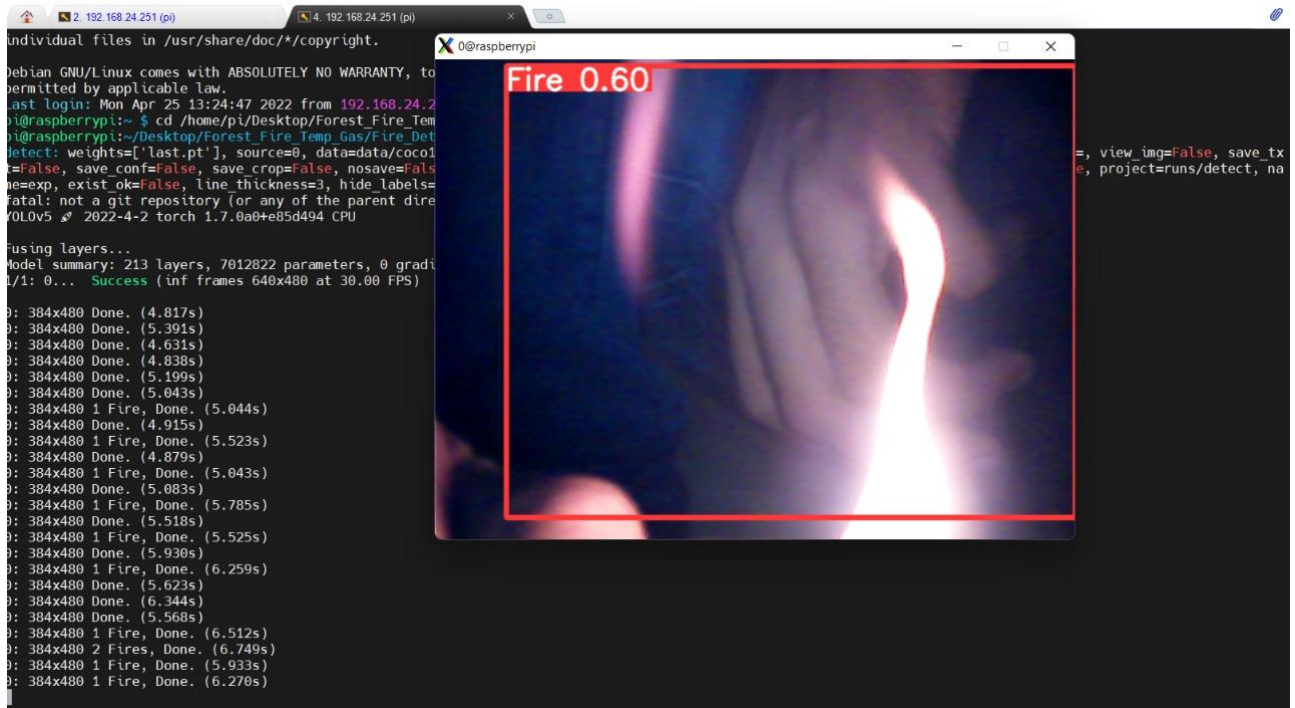

FIGURE.10.Output for Fire Detection

## XI. APPLICATIONS

In future, this approach can be extended for other disasters as well. The system can be used in various areas like

- Parking areas
- Road traffic congestions
- Agriculture
- Farming

## XII. CONCLUSION

Few years back the fire is detected through sensors or the other technique or by smoke. However, these strategies are currently old and aren't effective as a result of in these strategies the fire detects once it reaches most level and it absolutely was generally too late as a result of the damage was already done. To stop from this and to prevent fire once it starts with this project, we've got engineered a software system and hardware wherever you'll deploy in forests which might be used to detect and predict the occurrence of fire.

## ACKNOWLEDGMENT

We extend our gratitude to the Management, Dr. B. Chidhambararajan, Principal, Dr. M. Murugan, Vice Principal, Dr. Komal James, for the provision of laboratory facilities to complete our project successfully. Our sincere thanks to our project coordinator and panel members for their valuable guidance and motivation to achieve the objectives of the project fruitfully.

## References:

- [1] Yamagishi, H. and Yamaguchi, J.(n.d.). A contour fluctuation data processing method for fire flame detection using a color camera. 26th Annual Conference of the IEEE Industrial Electronics Society. IECON.IEEE International Conference on Industrial Electronics, Control and Instrumentation. 21st Century Technologies and Industrial, pp.824-829, 2000.
- [2] Pritam, D., and Dewan, J. H. (2017). Detection of fire using image processing techniques with LUV color space. 2nd International Conference for Convergence in Technology (I2CT), pp.1158-1162, 2017.
- [3] Seebamrungsat, J., Praising, S., and Riyamongkol, P. (2014). Fire detection in the buildings using image processing. 2014 Third ICT International Student Project Conference (ICT-ISPC), pp.95-98, 2014.
- [4] Azmil, M. S. A., Ya'acob, N., Tahar, K. N., and Sarnin, S. S. (2015). Wireless fire detection monitoring system for fire and rescue application. 2015 IEEE 11th International Colloquium on Signal Processing and Its Applications (CSPA), pp.84-89, 2015.
- [5] Md Saifudaullah Bin Bahrudin and Rosni Abu Kassim "Development of Fire Alarm System using Raspberry Pi and Arduino Uno" in International Conference on Electrical, Electronics and System Engineering ,2013, pp. 43-47, 2013.
- [6] Ku. R.A.Agrawal and Prof. S.T.Khandare "Fire Detection Using Image Processing" in International Journal of Advanced Engineering and Global Technology I Vol-03, Issue-12, pp. 1499-1503, 2015.
- [7] Nurul Shakira Bakri, Ramli Adnan, Abd Manan Samad and FazlinaAhmat Ruslan "A Methodology for Fire Detection Using Color Pixel Classification" in IEEE 14th International Colloquium on Signal Processing and its Applications (CSPA 2018), Penang, Malaysia, pp. 94-98, 2018.
- [8] Noorinder, Student Member IEEE, Jaspreet Singh, Member IEEE and EkambirSidhu, Member IEEE/IETE Raspberry Pi based Smart Fire Management System employing Sensor based Automatic Water Sprinkler in International Conference on Power and Embedded Drive Control (ICPEDC), 2017, pp.102-107.
- [9] Ahmed Imteaj, Tanveer Rahman, Muhammad Kamrul Hossain, Mohammed Shamsul Alam and Saad Ahmad Rahat an IoT based Fire Alarming and Authentication System for Workhouse using Raspberry Pi 3 in International Conference on Electrical, Computer and Communication Engineering (ECCE), February 16-18, 2017, Coks Bazar, Bangladesh, pp. 899-904.
- [10] K. Ramya, "Survey on an Intelligent AAA Device for Fire Detection" in International Journal of Advance Research, Ideas and Innovations in Technology (Volume 4, Issue 1), pp. 669-673, 2018.
- [11] Priyadarshini M Hanamaraddi\* et al, "A Literature Study on Image Processing for Forest Fire Detection", in (IJITR) INTERNATIONAL JOURNAL OF INNOVATIVE TECHNOLOGY AND RESEARCH Volume No.4, Issue No.1, December - January 2016, 2695 - 2700.
- [12] TurgayCelik Fast and Efficient Method for Fire Detection Using Image Processing in ETRI Journal, Volume 32, Number 6, December 2010, pp. 881-890.

Copyright protected @ ENGPAPER.COM and AUTHORS

[Engpaper Journal](#)



<https://www.engpaper.com>